

KOBELCO

SK500_{LC}



We Save You Fuel
Achieving a Low-Carbon Society

Power Meets Efficiency



SK500_{LC}

Higher fuel
efficiency
means
"Efficiency"

Increase in
productivity
means
"Power"

To urban centers, and to mines around the world. Kobelco's all-out innovation brings you durable earth-friendly construction machinery that's equal to any task, at sites all over the planet. Increased power and even greater fuel economy bring higher efficiency to any project. Kobelco SK500LC machines are also more durable than ever, able to withstand the rigors of the toughest job sites. It all adds up to new levels of value that are a step ahead of the times. Also, this machine conforms to Stage V Exhaust Emission Standards, thanks to its significantly reduced NOx* emissions. While focusing on the global environment of the future, Kobelco offers next-generation productivity to meet the need for lower life cycle costs and exceed the expectations of customers the world over.

* NOx: Nitrogen Oxide

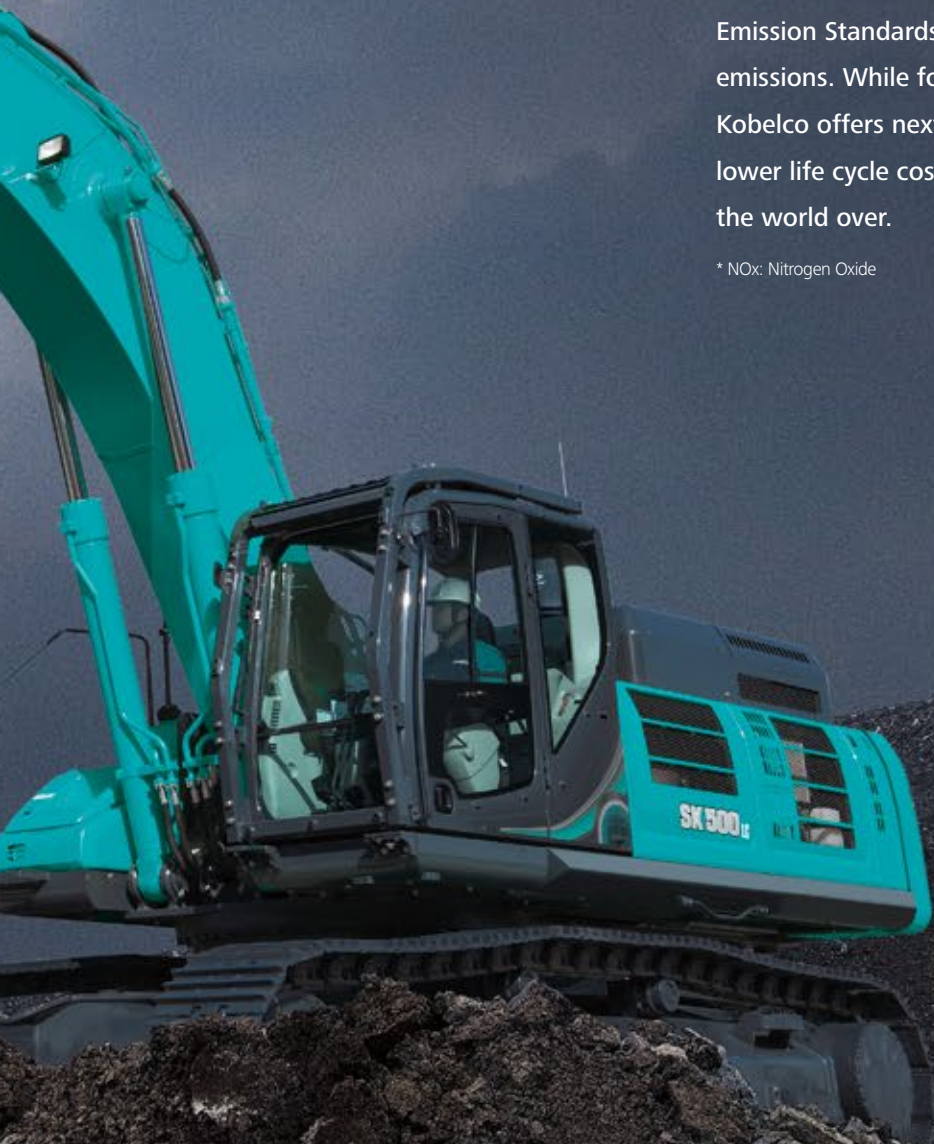

Evolution Continues, with Improved Fuel Efficiency.

Hydraulic System: Revolutionary Technology Saves Fuel

Arm Interflow System NEW

When lowering the boom, this system uses the downward force generated by the boom's weight to push fluid to the shovel arm. This greatly reduces the need to apply power from outside the system.

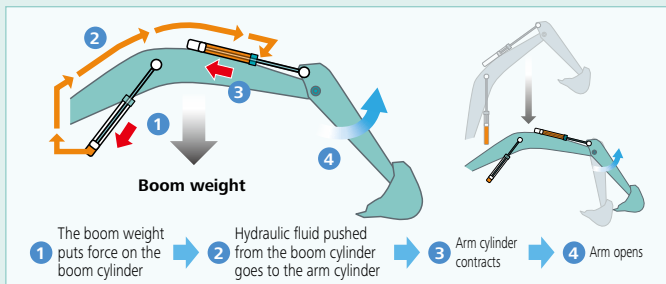

Hydraulic Circuit Reduces Energy Loss

We have made every effort to enhance fuel efficiency by minimizing hydraulic pressure resistance, improving the hydraulic line layout to control friction resistance loss and minimizing valve resistance.

Improved hydraulic piping is an effective means of reducing pressure loss.

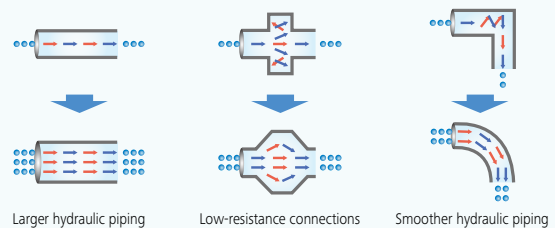

In Pursuit of Improved Fuel Efficiency

ECO-mode further reduces fuel consumption Operation Mode

Fuel consumption is lower in ECO-mode in comparison with the previous model (Generation 9).

■ Compared to previous models

E ECO-mode...About **6%** improvement

Always and Forever. Yesterday, Today, and Tomorrow. Obsessed with Fuel Efficiency.

Over the past 10 years, Kobelco has achieved an average reduction of about 36% in fuel consumption. And we vow to continue to lead in fuel efficiency.

■ Compared to SK480LC-6 model (2006)

E ECO-mode (SK500LC-10)...About **36%** improvement

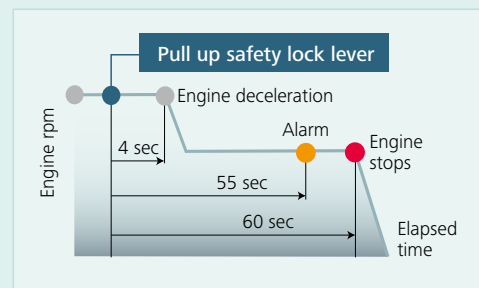

AIS (Auto Idle Stop)

If the boarding/disembarking lever is left up, the engine will stop automatically. This eliminates wasteful idling during standby, saving fuel and reducing CO₂ emissions as well.

Higher fuel efficiency means "Efficiency"

The new arm interflow system more efficiently controls hydraulic fluid flow, and significant reduction of in-line resistance and pressure loss boosts fuel efficiency. The engine, already well-known for its environmental performance has a new SCR* system, and its reduced NOx emissions means the engine now meets Stage V Standards.

* SCR: Selective Catalytic Reduction



Built to operate in tough working environment

Hydraulic Drive for Engine Cooling Fan; **NEW** Independent Oil Cooler Fan

Hydraulic drive optimizes the cooling fan rotation speed to improve fuel economy and reduce noise. Also, the independent oil cooler fan better matches cooling to the hydraulic oil temperature, for optimal oil temperature control.



Conforms to Stage V exhaust emissions standards

Reduces Fuel Consumption and Minimizes Exhaust Emissions

Hino engines are renowned for fuel efficiency and environmental performance, and KOBELCO has tuned them specifically for construction machinery.

The high-pressure common rail fuel injection system, the variable-geometry (VG) turbocharger, and the exhaust gas recirculation (EGR) system reduce particulate matter (PM) while the large EGR cooler greatly reduces the formation of nitrogen oxide (NOx) gases.



VG Turbo Reduces PM

The variable-geometry turbocharger adjusts air intake to maximize combustion efficiency. At low engine speeds the nozzles are closed, the turbo speed increased and air intake is boosted. This helps lower fuel consumption.

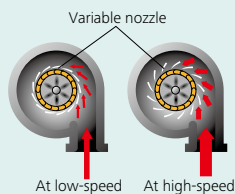

SCR System with Urea **NEW**

Engine exhaust system utilizes Selective Catalytic Reduction (SCR) to convert NOx* into harmless nitrogen and water emissions. SCR combined with a Diesel Particulate Filter (DPF) makes a much cleaner machine meeting U.S. EPA regulations for Stage V.

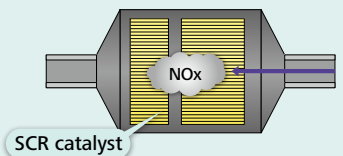

*80% cleaner than Tier IV interim

EGR Cooler Reduces NOx

Cooled exhaust gases from the EGR cooler are mixed with fresh air in the intake. The recirculated air lowers the combustion temperature which reduces NOx.

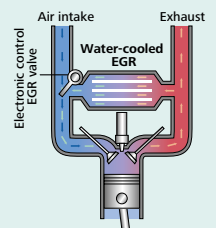

More Power and Higher Efficiency

The highly efficient hydraulic system minimizes fuel consumption while maximizing power. With nimble movement and ample digging power, this excavator promises to improve your job productivity.

Improved fuel efficiency contributes to high performance

Improved excavating load Digging Volume

This excavator offers dynamic digging force even as it minimizes fuel consumption rates, achieving class-leading work volume. H-mode, sometimes with an increased torque setting, delivers about 13% greater digging volume.

■ Max. Bucket Digging Force

Normal: **267 kN**
With power boost: **292 kN**

■ Max. Arm Crowding Force

Normal: **203 kN**
With power boost: **222 kN**

S S-mode...About **8%** improvement

H H-mode...About **13%** improvement



Get More Done Faster with Superior Operability

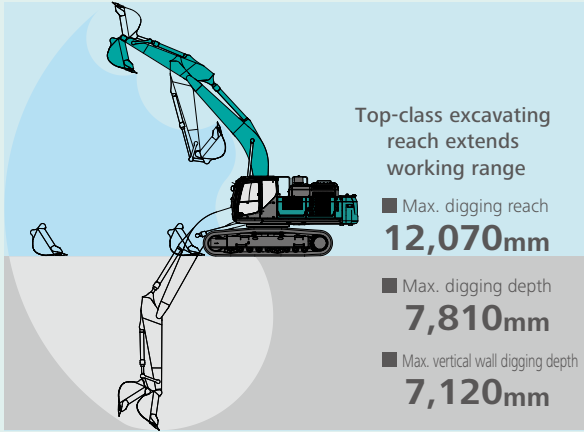

Top-class excavating reach extends working range

■ Max. digging reach
12,070mm

■ Max. digging depth
7,810mm

■ Max. vertical wall digging depth
7,120mm

Values are for HD arm (3.45m)

Piping for Quick Hitch (optional)



A quick hitch hydraulic line, which speeds up attachment changes, is available as an option.

A Light Touch on the Lever NEW Means Smoother, Less Tiring Work



It takes 25%* less effort to work the operation lever, which reduces fatigue over long working hours or continued operations.

*Compared to SK500LC-9

Top Class Traveling Force

Powerful traveling force and pulling force deliver plenty of speed when climbing slopes or negotiating bad roads, and the agility to change direction swiftly and smoothly.



■ Drawbar Pulling Force: **415kN**

Operator-friendly Features Include Controls that Are Easy to See, Easy to Use



Multi-Display in Color

Brilliant colors and graphic displays are easy to recognize on the LCD multi-display in the console. The display shows fuel consumption, maintenance intervals, and more.

- 1 Analog gauge provides an intuitive reading of fuel level and engine water temperature
- 2 Green indicator light shows low fuel consumption during operation
- 3 PM accumulation display (left)/Urea level gauge (right)
- 4 Fuel consumption/Switch indicator for rear camera images
- 5 Digging mode switch
- 6 Monitor display switch

One-Touch Attachment Mode Switch

A simple flick of a switch converts the hydraulic circuit and flow amount to match attachment changes. Icons help the operator to confirm the proper configuration at a glance.



PM accumulation display
Urea level gauge

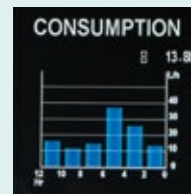

Fuel consumption

| | INTERVAL | REMAINING TIME | EXCHANGE DATE |
|-------------|----------|----------------|---------------|
| ENGINE OIL | 500 | 498 | --/-- |
| FUEL FILTER | 500 | 498 | --/-- |
| HYD. FILTER | 1000 | 998 | --/-- |
| HYD. OIL | 5000 | 4998 | --/-- |

Maintenance



Breaker mode

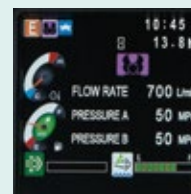

Nibbler mode

Increased Power, with Enhanced Durability to Maintain the Machine's Value

Improved Filtration System Reliability

Clean, contaminant-free fuel and hydraulic fluid are essential to stable performance. The improved filtration systems reduce the risk of mechanical trouble and enhance longevity and durability.

Hydraulic Fluid Filter **NEW**

Recognized as the best in the industry, our premium fine filter separates out even the smallest particles. New cover prevents contamination when changing filters.



Hydraulic Fluid Filter Clog **NEW** Detector

Pressure sensors at the inlet and outlet of the hydraulic fluid filter monitor differences in pressure to determine the degree of clogging. If the difference in pressure exceeds a predetermined level, a warning appears on the multi-display, so any contamination can be removed from the filter before it reaches the hydraulic fluid reservoir.

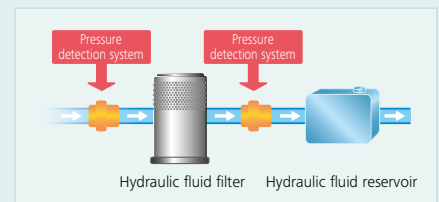

Double-Element Air Cleaner

The large-capacity element features a double-filter structure that keeps the engine running clean even in industrial environments.



Fuel Filter **NEW**

The pre-filter, with built-in water separator maximizes filtering performance.

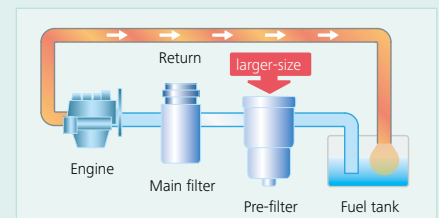

Increase in
productivity
means
"Power"

Structural design increases strength,
while eliminating hydraulic problems.
Enhanced durability takes
productivity to a new level.



Increased Filtering Capacity for Hydraulic Oil **NEW**

Two filters are installed for returning hydraulic oil, to curb clogging and increase the durability and reliability of the hydraulic equipment.



Pump Drain Filter **NEW**

Newly installed pump drain filter boosts pump reliability.



Pilot Filter

A new cartridge-type pilot filter simplifies maintenance.



Comfortable Cab Is Now Safer than Ever

A work environment that is quieter and more comfortable. A cab that puts the operator first is key to improved safety.



Comfort

Super-Airtight Cab



The high level of air-tightness keeps dust out of the cab.

Quiet Inside

The high level of air-tightness ensures a quiet, comfortable cabin interior.

Low Vibration

Coil springs absorb small vibrations, and high suspension mounts filled with silicone oil reduce heavy vibration. The long stroke achieved by this system provides excellent protection from vibration.

Twice the stroke of a conventional mount

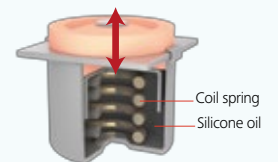

Broad View Liberates the Operator

The front window features one large piece of glass without a center pillar on the right side for a wide, unobstructed view.

Air Conditioner NEW Register behind the Seat



The large air-conditioner has registers on the back pillars that blow from behind and to the right and left of the operator's seat. They can be adjusted to put a direct flow of cool/warm air on the operator, which means a more comfortable operating environment.

More Comfortable Seat Means Higher Productivity



Seat suspension absorbs vibration



Seat recliner can be pushed back flat



Double slides allow adjustment for optimum comfort



Large Cab Is Easy to Get In and Out of

The expanded cab provides plenty of room for a large door, more headroom and smoother entry and exit.

Interior Equipment Adds to Comfort and Convenience



AM/FM Bluetooth®(hands-free) radio



USB connector/12V power outlet

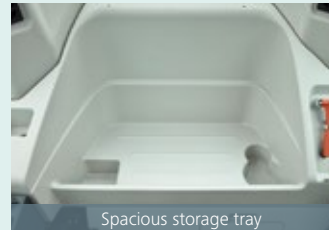

Spacious storage tray

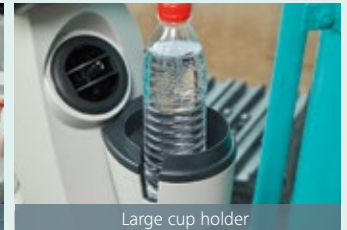

Large cup holder

Safety

ROPS Cab

ROPS (Roll-Over-Protective Structure)-compliant cab clears ISO standards (ISO-12117-2: 2008) and ensures greater safety for the operator should the machine tip over.



TOP Guard is fitted as standard.

Expanded Field of View for Greater Safety



Rear view camera Right side view camera (Option)

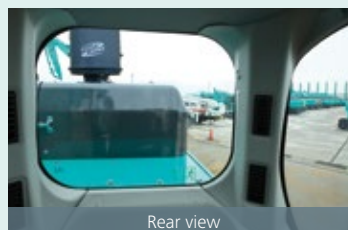

Rear view

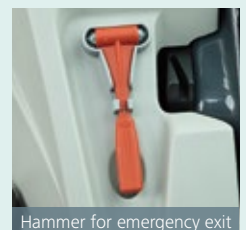

Hammer for emergency exit

Right Side Camera Fitted as Option

In addition to the existing rear-view camera, a camera for the right side is fitted as option for easy safety checks all around the machine.

Rear view shows the area directly behind the cab.

GEOSCAN

Excavator Remote Monitoring System



Direct Access to Operational Status

Location Data

• Accurate location data can be obtained even from sites where communications are difficult.

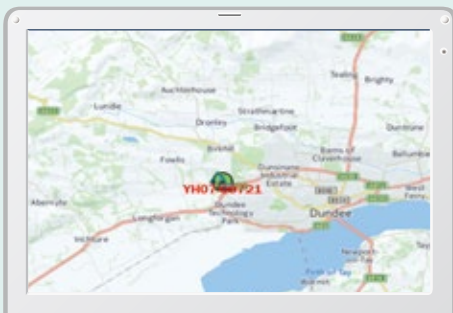

Latest location

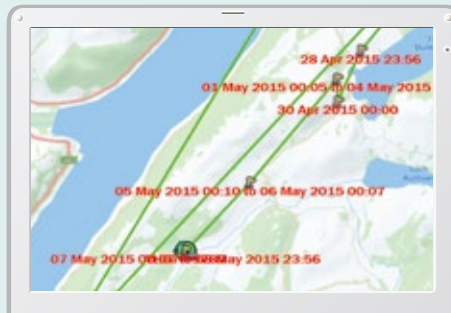

Location records

| Period | Working Hrs | Ratio |
|------------------------------|-------------|-------|
| 11 Apr, 2015 to 10 May, 2015 | 169 Hrs | 100 % |
| Total Working Hrs | 72.2 Hrs | 43 % |
| Digging Hrs | 18.3 Hrs | 11 % |
| Idle Hrs | 15.9 Hrs | 9 % |
| Opt Att Hrs | 62.5 Hrs | 37 % |
| Crane Mode Hrs | 0 Hrs | 0 % |

Work data

Operating Hours

- A comparison of operating times of machines at multiple locations shows which locations are busier and more profitable.
- Operating hours on site can be accurately recorded, for running time calculations needed for rental machines, etc.

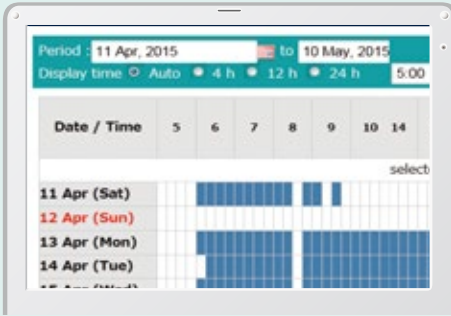

Daily report

Fuel Consumption Data

- Data on fuel consumption and idling times can be used to indicate improvements in fuel consumption.

| Work mode | Working Hrs | Total Fuel Consumption |
|--------------|---------------|------------------------|
| H mode | 2:06 | 24.5 L |
| S mode | 0:00 | 0.0 L |
| E mode | 169:19 | 1489.7 L |
| TOTAL | 171:25 | 1514.2 L |

Fuel consumption

Graph of Work Content

- The graph shows how working hours are divided among different operating categories, including digging, idling, traveling and optional operations.



Work status

Maintenance Data and Warning Alerts

Machine Maintenance Data

- Provides maintenance status of separate machines operating at multiple sites.
- Maintenance data is also relayed to KOBELCO service personnel, for more efficient planning of periodic servicing.

| Model | Serial No. | Hour Meter | Engine Oil |
|----------------------|------------|------------|------------|
| SK135SRLC-3/SK140SRL | YH07-09721 | 0.38/0.35 | 734 Hr |
| SK135SRLC-3/SK140SRL | YH07-09789 | 0.38/0.35 | 73 Hr |
| SK210LC-9 | YQ13-10454 | 0.8/0.7 | 960 Hr |
| SK210LC-9 | YQ13-10481 | 0.8/0.7 | 549 Hr |
| SK75SR- | YT08-30374 | | |

Maintenance

Warning Alerts

- This system warns an alert if an anomaly is sensed, preventing damage that could result in machine downtime.

Alarm Information Can Be Received through E-mail

- Alarm information or maintenance notice can be received through E-mail, using a computer or cell phone.



Alarm messages can be received on mobile device.

Daily/Monthly Reports

- Operational data downloaded onto a computer helps in formulating daily and monthly reports.

Security System

Engine Start Alarm

- The system can be set an alarm if the machine is operated outside designated time.

Engine start alarm outside prescribed work time

Area Alarm

- It can be set an alarm if the machine is moved out of its designated area to another location.

Alarm for outside of reset area



Easy, On-the-Spot Maintenance NEW

There is ample space in the engine compartment for a mechanic to do maintenance work inside. The distance between steps are lower so entry and exit is easier. And the mechanic can work in comfort, without contortions or unnatural body positions. Finally, the hood is lighter and easier to raise and lower.



Step/Hand rail



Urea tank



Double-element air cleaner

Ground Level Access

Laid out for easy access to radiator and cooling system elements.



Left side

Maintenance Work, Daily Checks, Etc., Can Be Done from Ground Level

The layout allows for easy access from the ground for many daily checks and regular maintenance tasks.



Engine oil filter



Pilot filter



Pump drain filter



Right side



Pre-filter with water separator

- ① Engine oil filter
- ② Pilot filter
- ③ Pump drain filter
- ④ Pre-filter with water separator

Efficient Maintenance Keeps the Machine in Peak Operating Condition



Machine Information Display Function

Examples of displaying maintenance information

- Displays only the maintenance information that's needed, when it's needed
- Self-diagnostic function provides early-warning detection and display of electrical system malfunctions
- Service-diagnostic function makes it easier to check the status of the machine
- Record function for previous breakdowns including irregular and transient malfunction

More Efficient Maintenance Inside the Cab

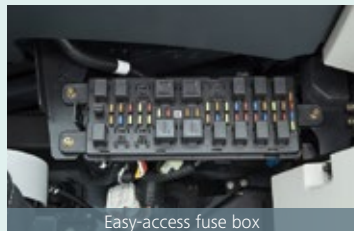

Easy-access fuse box

More finely differentiated fuses make it easier to locate malfunctions.

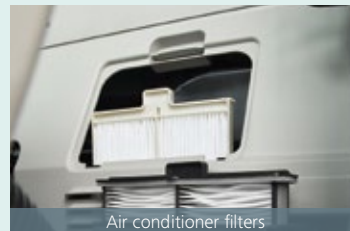

Air conditioner filters

Internal and external air conditioner filters can be easily removed without tools for cleaning.



DPF reactivation switch

If the monitor warning goes off, the filter should be reactivated manually using a switch.

Easy Cleaning



Crawler frame

Special sloped crawler side frame design is easily cleaned of mud.



Detachable two-piece floor mat

Detachable two-piece floor mat with handles for easy removal. A floor drain is located under the floor mat.

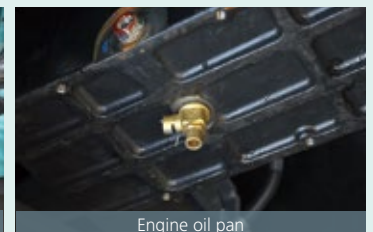

Engine oil pan

Engine oil pan equipped with drain valve.

Long-life hydraulic oil:
5,000 hours

Long-Interval Maintenance

Long-life hydraulic oil reduces cost and labor.

Replacement cycle:
1,000 hours

Highly Durable Premium-fine Filter

The high-capacity hydraulic oil filter incorporates glass fiber with superior cleaning power and durability.



Engine

| | |
|--------------------|---|
| Model | HINO P11C-VN |
| Type | Water-cooled, 4cycle 6cylinder direct injection type diesel engine with intercooler turbo-charger (Stage V certified) |
| No. of cylinders | 6 |
| Bore and stroke | 122 mm × 150 mm |
| Displacement | 10.52 L |
| Rated power output | Net 271 kW/1,850 min ⁻¹ (ISO 14396 : without fan) |
| Max. torque | Net 1,470 N·m/1,400 min ⁻¹ (ISO 14396 : without fan) |

Hydraulic System

| Pump | |
|----------------------------|---|
| Type | Two variable displacement pumps + One gear pump |
| Max. discharge flow | 2 × 370 L/min, 1 × 63.5 L/min Extra gear pump 1 × 60 L/min |
| Relief valve setting | |
| Excavating circuits (main) | 31.4 Mpa |
| Power boost | 34.3 Mpa |
| Travel circuit | 34.3 Mpa |
| Swing circuit | 25.8 Mpa |
| Pilot control circuit | 5.0 Mpa |
| Pilot control pump | Gear type |
| Main control valve | 8-spool |
| Oil cooler | Air cooled type |

Swing System

| | |
|------------------------|--|
| Swing motor | Axial piston motor |
| Parking brake | Wet multiple plate, hydraulic operated automatically |
| Swing speed | 7.6 min ⁻¹ |
| Swing torque | 183 kN·m |
| Tail swing radius | 3,800 mm |
| Min front swing radius | 5,140 mm |

Attachments

Backhoe bucket and combination

| Use | | | Backhoe bucket | | | | |
|-----------------|-----------------------------|----------------|----------------|----------------|---------------|-----------------|-------|
| | | | Heavy digging | Normal digging | Light digging | Mass Excavating | |
| Bucket capacity | ISO heaped | m ³ | 1.9 | 2.1 | 2.1 | 2.4 | 3.4 |
| Struck | | m ³ | 1.4 | 1.5 | 1.5 | 1.7 | 2.5 |
| Opening width | With side cutters | mm | 1,590 | 1,660 | 1,750 | 1,980 | 1,990 |
| | Without side cutters | mm | 1,510 | 1,580 | 1,630 | 1,860 | 1,870 |
| No. of teeth | | | 4 | 5 | 5 | 5 | 6 |
| Bucket weight | | kg | 2,150 | 2,270 | 1,560 | 1,690 | 2,340 |
| Combination | 3.0m short arm | | ○ | ◎ | ◎ | △ | × |
| | 3.45m standard arm | | ◎ | △ | △ | × | × |
| | 4.04m long arm | | △ | × | × | × | × |
| | 6.3m ME boom and 2.4 ME arm | | × | × | × | × | ○* |

◎ Standard ○ Recommend △ Loading only × Not recommended

*Mass Excavating specs should be used for light-digging.

Travel System

| | |
|-------------------------|-----------------------------------|
| Travel motors | 2 x axial-piston, two-step motors |
| Travel brakes | Hydraulic brake per motor |
| Parking brakes | Wet multiple plate |
| Travel shoes | 50 each side |
| Travel speed (high/low) | 5.4/3.4 km/h |
| Drawbar pulling force | 415 kN |
| Gradeability | 70 % (35 deg) |
| Ground clearance | 510 mm |

Cab & Control

Cab

All-weather, sound-suppressed steel cab mounted on the high suspension mounts filled with silicone oil and equipped with a heavy, insulated floor mat.

Control

Two hand levers or two foot pedals for forward and backward operations of each track independently.

Boom, Arm & Bucket

| | |
|-----------------|-------------------|
| Boom cylinders | 170 mm × 1,590 mm |
| Arm cylinder | 190 mm × 1,970 mm |
| Bucket cylinder | 160 mm × 1,410 mm |

Refilling Capacities & Lubrications

| | |
|-----------------------|------------------------|
| Fuel tank | 638 L |
| Cooling system | 47.4 L |
| Engine oil | 42.5 L |
| Travel reduction gear | 2×15 L |
| Swing reduction gear | 2×5 L |
| Hydraulic oil tank | 371 L tank oil level |
| | 631 L hydraulic system |
| Urea tank | 83 L |



Working Ranges

Unit: m

| Boom | Arm | ME 6.3m | | 7.0 m* | |
|--|-----|-----------|--------------|------------------|--------------|
| | | ME 2.4Arm | Short 3.0Arm | Standard 3.45Arm | Long 4.04Arm |
| Range | | | | | |
| a- Max. digging reach | | 10.88 | 11.77 | 12.07 | 12.61 |
| b- Max. digging reach at ground level | | 10.63 | 11.54 | 11.84 | 12.4 |
| c- Max. digging depth | | 6.48 | 7.36 | 7.81 | 8.4 |
| d- Max. digging height | | 10.92 | 11.16 | 10.93 | 11.14 |
| e- Max. dumping clearance | | 6.92 | 7.72 | 7.58 | 7.79 |
| f- Min. dumping clearance | | 3.11 | 3.22 | 2.77 | 2.18 |
| g- Max. vertical wall digging depth | | 5.58 | 6.68 | 7.12 | 7.5 |
| h- Min. swing radius | | 4.78 | 5.28 | 5.14 | 5.21 |
| i- Horizontal digging stroke at ground level | | 3.59 | 5.21 | 6.1 | 7.07 |
| j- Digging depth for 2.4 m (8') flat bottom | | 6.31 | 7.21 | 7.67 | 8.27 |
| Bucket capacity ISO heaped m ³ | | 3.4 | 2.1 | 1.9 | 1.6 |

*As boom hoot of MVLC is 120mm higher than rigid type, working range of MVLC rise 120mm higher than rigid type.

Digging Force (ISO 6015)

Unit: kN

| Arm length | ME 2.4Arm | Short 3.0Arm | Standard 3.45Arm | Long 4.04Arm |
|----------------------|-----------|--------------|------------------|--------------|
| Bucket digging force | 288/312* | 266/291* | 267/292* | 289/264* |
| Arm crowding force | 247/270* | 223/244* | 203/222* | 198/181* |

*Power Boost engaged.

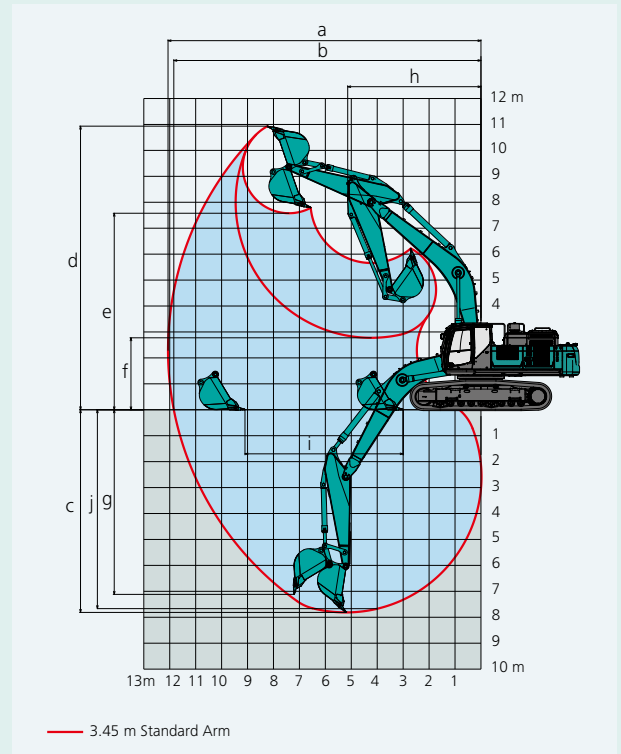

Dimensions

Unit: mm

| Arm length | ME 2.4Arm | Short 3.0Arm | Standard 3.45Arm | Long 4.04Arm |
|--|-----------|--------------|------------------|--------------|
| A Overall length | 11,910 | 12,170 | 12,140 | 12,190 |
| B Overall height (to top of boom) | 4,240 | 3,780 | 3,570 | 3,720 |
| C Overall width | 3,350 | | | |
| D Overall height (to top of cab) | 3,380 | | | |
| E Ground clearance of rear end* | 1,340* | | | |
| F Ground clearance* | 510* | | | |
| G Tail swing radius | 3,880 | 3,800 | | |
| G' Distance from center of swing to rear end | 3,880 | 3,800 | | |
| H Tumbler distance | 4,400 | | | |
| I Overall length of crawler | 5,450 | | | |
| J Track gauge | 2,750 | | | |
| K Shoe width | 600 | | | |
| L Overall width of upperstructure | 3,110 | | | |

*Without including height of shoe lug.

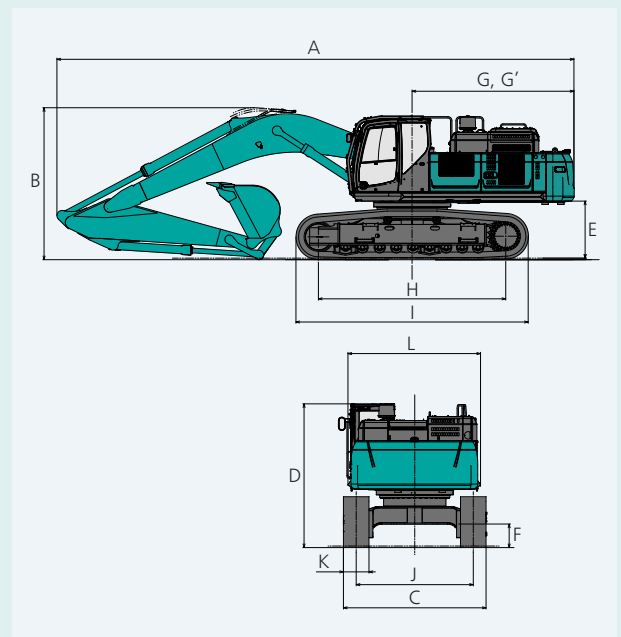

Operating Weight & Ground Pressure

In standard trim, with standard boom, 3.45 m arm, and 1.9 m³ ISO heaped bucket

| Shaped | Triple grouser shoes (even height) | | |
|--------------------------|------------------------------------|--------|--------|
| Shoe width | mm | 600 | 800 |
| Overall width of crawler | mm | 3,350 | 3,550 |
| Ground pressure | kPa | 87 | 67 |
| Operating weight | kg | 50,600 | 51,900 |

In standard trim, with 6.3 m ME boom, 2.4 m ME arm, and 3.4 m³ ISO heaped bucket

| Shaped | Triple grouser shoes (even height) | | |
|--------------------------|------------------------------------|--------|--------|
| Shoe width | mm | 600 | 800 |
| Overall width of crawler | mm | 3,350 | 3,550 |
| Ground pressure | kPa | 89 | 69 |
| Operating weight | kg | 52,000 | 53,300 |

Lift Capacities

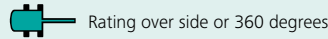
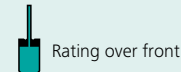
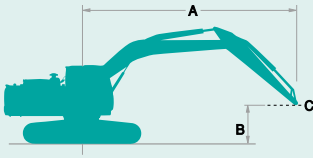

A: Reach from swing centerline to arm top
 B: Arm top height above/below ground
 C: Lift point
 Bucket: Without bucket
 Relief valve setting: 34.3 MPa

| SK500LC-10 | | Boom: 7.0 m Arm: 3.45 m Bucket: without Counterweight: 9,800 kg Shoe: 600 mm (Heavy Lift) | | | | | | | | | | | | | | |
|------------|----|---|---------------------------------|-------------------|---------------------------------|-------------------|---------------------------------|-------------------|---------------------------------|-------------------|---------------------------------|-------------------|---------------------------------|---------|---------|--------|
| A \ B | | 3.0 m | | 4.5 m | | 6.0 m | | 7.5 m | | 9.0 m | | At Max. Reach | | Radius | | |
| | | Rating over front | Rating over side or 360 degrees | Rating over front | Rating over side or 360 degrees | Rating over front | Rating over side or 360 degrees | Rating over front | Rating over side or 360 degrees | Rating over front | Rating over side or 360 degrees | Rating over front | Rating over side or 360 degrees | | | |
| 9.0m | kg | | | | | | | | | | | | | *10,330 | *10,330 | 7.76m |
| 7.5m | kg | | | | | | | | | | | | | *10,080 | 8,840 | 8.85m |
| 6.0m | kg | | | | | | | | | | | | | *9,890 | 7,630 | 9.59m |
| 4.5m | kg | | | *18,050 | *18,050 | *13,820 | *13,820 | *11,760 | 10,990 | *10,630 | 8,540 | | | *9,980 | 6,940 | 10.04m |
| 3.0m | kg | | | *22,790 | 21,530 | *16,120 | 14,360 | *13,020 | 10,470 | *11,310 | 8,030 | | | *10,330 | 6,570 | 10.26m |
| 1.5m | kg | | | *14,790 | *14,790 | *18,000 | 13,590 | *14,160 | 10,020 | *11,960 | 7,780 | | | 10,380 | 6,450 | 10.25m |
| G.L. | kg | | | *18,080 | *18,080 | *19,060 | 13,140 | *14,930 | 9,710 | 12,360 | 7,590 | | | 10,640 | 6,580 | 10.01m |
| -1.5m | kg | *13,040 | *13,040 | *25,670 | 19,880 | *19,230 | 12,980 | *15,140 | 9,570 | 12,290 | 7,530 | | | 11,380 | 7,010 | 9.53m |
| -3.0m | kg | *22,230 | *22,230 | *24,140 | 20,100 | *18,440 | 13,050 | *14,550 | 9,610 | | | | | *11,800 | 7,900 | 8.76m |
| -4.5m | kg | *28,120 | *28,120 | *21,140 | 20,570 | *16,340 | 13,360 | *12,370 | 9,930 | | | | | *11,980 | 9,730 | 7.63m |

| SK500LC-10 | | Boom: 7.0 m Arm: 3.0 m Bucket: without Counterweight: 9,800 kg Shoe: 600 mm (Heavy Lift) | | | | | | | | | | | | | | |
|------------|----|--|---------------------------------|-------------------|---------------------------------|-------------------|---------------------------------|-------------------|---------------------------------|-------------------|---------------------------------|-------------------|---------------------------------|---------|---------|-------|
| A \ B | | 3.0 m | | 4.5 m | | 6.0 m | | 7.5 m | | 9.0 m | | At Max. Reach | | Radius | | |
| | | Rating over front | Rating over side or 360 degrees | Rating over front | Rating over side or 360 degrees | Rating over front | Rating over side or 360 degrees | Rating over front | Rating over side or 360 degrees | Rating over front | Rating over side or 360 degrees | Rating over front | Rating over side or 360 degrees | | | |
| 9.0m | kg | | | | | | | | | | | | | *11,290 | *11,290 | 7.36m |
| 7.5m | kg | | | | | | | | | | | | | *10,930 | 9,350 | 8.51m |
| 6.0m | kg | | | | | | | | | | | | | *11,330 | *11,330 | 9.27m |
| 4.5m | kg | | | *19,670 | *19,670 | *14,670 | *14,670 | *12,350 | 10,910 | *11,150 | 8,280 | | | *10,910 | 7,270 | 9.74m |
| 3.0m | kg | | | | | *16,870 | 14,190 | *13,530 | 10,420 | *11,730 | 8,030 | | | 10,990 | 6,890 | 9.96m |
| 1.5m | kg | | | | | *18,550 | 13,520 | *14,560 | 10,010 | *12,280 | 7,800 | | | 10,880 | 6,790 | 9.95m |
| G.L. | kg | | | *13,600 | *13,600 | *19,340 | 13,170 | *15,180 | 9,750 | 12,430 | 7,660 | | | 11,200 | 6,950 | 9.70m |
| -1.5m | kg | *10,220 | *10,220 | *23,790 | 20,090 | *19,210 | 13,090 | *15,180 | 9,660 | *12,260 | 7,660 | | | *11,810 | 7,460 | 9.21m |
| -3.0m | kg | *22,180 | *22,180 | *23,330 | 20,360 | *18,090 | 13,220 | *14,240 | 9,770 | | | | | *11,970 | 8,510 | 8.41m |
| -4.5m | kg | *25,400 | *25,400 | *19,810 | *19,810 | *15,410 | 13,610 | | | | | | | *11,760 | 10,720 | 7.22m |

| SK500LC-10 | | Boom: 7.0 m Arm: 4.04 m Bucket: without Counterweight: 9,800 kg Shoe: 600 mm (Heavy Lift) | | | | | | | | | | | | | | | | | |
|------------|----|---|---------------------------------|-------------------|---------------------------------|-------------------|---------------------------------|-------------------|---------------------------------|-------------------|---------------------------------|-------------------|---------------------------------|-------------------|---------------------------------|---------------|---------|--------|--------|
| A \ B | | 1.5 m | | 3.0 m | | 4.5 m | | 6.0 m | | 7.5 m | | 9.0 m | | 10.5 m | | At Max. Reach | | Radius | |
| | | Rating over front | Rating over side or 360 degrees | Rating over front | Rating over side or 360 degrees | Rating over front | Rating over side or 360 degrees | Rating over front | Rating over side or 360 degrees | Rating over front | Rating over side or 360 degrees | Rating over front | Rating over side or 360 degrees | Rating over front | Rating over side or 360 degrees | | | | |
| 9.0m | kg | | | | | | | | | | | | | | | | *8,740 | *8,740 | 8.47m |
| 7.5m | kg | | | | | | | | | | | | | | | | *9,090 | 8,720 | 9.48m |
| 6.0m | kg | | | | | | | | | | | | | | | | *9,310 | 8,580 | 10.17m |
| 4.5m | kg | | | | | | | | | *10,870 | *10,870 | *9,900 | 8,320 | *9,070 | 6,420 | *8,230 | 6,310 | 10.60m | |
| 3.0m | kg | | | | | *20,700 | *20,700 | *14,970 | 14,520 | *12,210 | 10,500 | *10,660 | 8,000 | *9,760 | 6,280 | *8,490 | 5,980 | 10.80m | |
| 1.5m | kg | | | | | *19,900 | *19,900 | *17,090 | 13,630 | *13,480 | 9,980 | *11,410 | 7,700 | 9,920 | 6,120 | *8,980 | 5,870 | 10.79m | |
| G.L. | kg | | | *6,590 | *6,590 | *19,630 | *19,630 | *18,470 | 13,050 | *14,440 | 9,600 | *11,990 | 7,460 | 9,800 | 6,010 | 9,710 | 5,960 | 10.57m | |
| -1.5m | kg | *8,670 | *8,670 | *12,720 | *12,720 | *24,690 | 19,550 | *19,000 | 12,780 | *14,890 | 9,390 | 12,100 | 7,340 | | | 10,290 | 6,300 | 10.11m | |
| -3.0m | kg | *14,910 | *14,910 | *19,830 | *19,830 | *24,790 | 19,670 | *18,630 | 12,760 | *14,660 | 9,360 | *11,760 | 7,370 | | | *10,990 | 6,990 | 9.40m | |
| -4.5m | kg | | | *29,250 | *29,250 | *22,430 | 20,040 | *17,130 | 12,970 | *13,330 | 9,540 | | | | | *11,300 | 8,340 | 8.35m | |
| -6.0m | kg | | | | | *18,040 | *18,040 | *13,620 | 13,500 | | | | | | | *11,240 | *11,240 | 6.81m | |

| SK500LC-10 | | ME Boom: 6.3 m ME Arm: 2.4 m Bucket: without Counterweight: 11,200 kg Shoe: 600 mm (Heavy Lift) | | | | | | | | | | | | | |
|------------|----|---|---------------------------------|-------------------|---------------------------------|-------------------|---------------------------------|-------------------|---------------------------------|-------------------|---------------------------------|--------|---------|---------|-------|
| A \ B | | 3.0 m | | 4.5 m | | 6.0 m | | 7.5 m | | At Max. Reach | | Radius | | | |
| | | Rating over front | Rating over side or 360 degrees | Rating over front | Rating over side or 360 degrees | Rating over front | Rating over side or 360 degrees | Rating over front | Rating over side or 360 degrees | Rating over front | Rating over side or 360 degrees | | | | |
| 9.0m | kg | | | | | | | | | | | | *14,020 | *14,020 | 5.63m |
| 7.5m | kg | | | | | | | | | | | | *11,920 | *11,920 | 7.07m |
| 6.0m | kg | | | | | | | | | | | | *11,010 | 10,850 | 7.97m |
| 4.5m | kg | | | | | *13,950 | *13,950 | *12,950 | 12,060 | | | | *10,660 | 9,640 | 8.52m |
| 3.0m | kg | | | | | *17,570 | 15,470 | *14,400 | 11,340 | | | | *10,690 | 9,060 | 8.77m |
| 1.5m | kg | | | | | *19,030 | 14,860 | *15,170 | 11,000 | | | | *11,080 | 8,950 | 8.76m |
| G.L. | kg | | | | | *19,550 | 14,560 | *15,440 | 10,820 | | | | *11,920 | 9,300 | 8.48m |
| -1.5m | kg | | | | | *24,790 | 22,260 | *18,920 | 14,560 | | | | *13,360 | 10,260 | 7.90m |
| -3.0m | kg | *27,610 | *27,610 | *21,650 | *21,650 | *16,570 | 14,880 | | | | | | *12,960 | 12,400 | 6.95m |

Notes:

- Do not attempt to lift or hold any load that is greater than these lift capacities at their specified lift point radius and heights. Weight of all accessories must be deducted from the above lift capacities.
- Lift capacities are based on machine standing on level, firm, and uniform ground. User must make allowance for job conditions such as soft or uneven ground, out of level conditions, side loads, sudden stopping of loads, hazardous conditions, experience of personnel, etc.
- Arm top defined as lift point.
- The above lift capacities are in compliance with ISO 10567. They do not exceed 87% of hydraulic lift capacity or 75% of tipping load. Lift capacities marked with an asterisk (*) are limited by hydraulic capacity rather than tipping load.
- Operator should be fully acquainted with the Operator's and Maintenance Instructions before operating this machine. Rules for safe operation of equipment should be adhered to at all times.
- Lift capacities apply to only machine as originally manufactured and normally equipped by KOBELCO CONSTRUCTION MACHINERY CO., LTD.

STANDARD EQUIPMENT

ENGINE

- Engine, HINO P11C-VN, diesel engine with turbocharger and intercooler
- Automatic engine deceleration
- Auto Idle Stop (AIS)
- Batteries (2 x 12V - 112Ah)
- Starting motor (24V - 6 kW), 60 amp alternator
- Automatic engine shut-down for low engine oil pressure
- Engine oil pan drain cock
- Double element air cleaner
- Refueling pump

CONTROL

- Working mode selector (H-mode, S-mode and ECO-mode)
- Power Boost
- Heavy lift
- Boom and arm safety valve
- N&B piping (without ME specification)

SWING SYSTEM & TRAVEL SYSTEM

- Swing rebound prevention system
- Straight propel system
- Two-speed travel with automatic shift down
- Sealed & lubricated track links
- Grease-type track adjusters
- Automatic swing brake
- Travel alarm

HYDRAULIC

- Arm regeneration system
- Auto warm up system
- Aluminum hydraulic oil cooler
- Hydraulic fluid filter clog detector
- Quick hitch piping (without ME ver.)

MIRRORS, LIGHTS & CAMERAS

- Rearview mirror
- Three front working lights
- Rear view camera

CAB & CONTROL

- Two control levers, pilot-operated
- Horn, electric
- Cab light (interior)
- Luggage tray
- Large cup holder
- Detachable two-piece floor mat
- Headrest
- Handrails
- Intermittent windshield wiper with double-spray washer
- Skylight
- Tinted safety glass
- Pull-up type front window and removable lower front window
- Easy-to-read multi-display color monitor
- Automatic air conditioner
- Emergency escape hammer
- Mechanical suspension seat
- Radio (AUX & Bluetooth®)
- USB pin
- TOP guard (ISO 10262:1998)
- GEOSCAN
- Lower Under Cover

OPTIONAL EQUIPMENT

- Mass Excavator specification
- Various optional arms
- Wide range of shoes
- Additional track guide
- Two cab lights
- Air suspension seat
- Rain visor (may interfere with bucket action)

- Cab guard
- Hydraulic pressure adjustment function for N&B piping
- Right-side view camera
- Multi control valve
- Extra piping (Applicable for 7.0m boom)
- N&B piping for ME specification

Note: Standard and optional equipment may vary. Consult your KOBELCO dealer for specifics. Bluetooth® is a registered trademark of the Bluetooth SIG Inc.

Note: This catalog may contain attachments and optional equipment that are not available in your area. And it may contain photographs of machines with specifications that differ from those of machines sold in your areas. Please consult your nearest KOBELCO distributor for those items you require. Specialist equipment is needed to use this machine in demolition work. Before using it please contact your KOBELCO dealer. Due to our policy of continuous product improvements all designs and specifications are subject to change without advance notice. Copyright by **KOBELCO CONSTRUCTION MACHINERY CO., LTD.** No part of this catalog may be reproduced in any manner without notice.

KOBELCO CONSTRUCTION MACHINERY CO., LTD.

17-1, Higashigotanda 2-chome, Shinagawa-ku, Tokyo 141-8626 JAPAN
Tel: +81 (0) 3-5789-2146 Fax: +81 (0) 3-5789-2135
www.kobelcocm-global.com

Inquiries To: