

KOBELCO

SK140SRD-7

Performance  Design

Multi-dismantling machine

SK140SRD



We Save You Fuel
Achieving a Low-Carbon Society

Performance Design

PERFORMANCE — Improved power and speed, and a relentless pursuit of efficiency and productivity.

DESIGN — The operator-first design is without compromise, resulting in intuitive ease of use and superior comfort.

By combining these two principles, KOBELCO has raised the bar with the SK140SRD, the new multi-use dismantling machine. Purpose-built with specialised equipment for scrap and metal demolition, this machine brings any dismantling operation to the next level.

KOBELCO excavators continue to provide an unforgettable experience for the operator, built to tackle any challenge.



Next Level Power and Beautiful Simplicity

A High-Output Engine Compliant Meeting the Latest Emissions Regulations

A significant increase in engine output. The high performance engine improves all aspects of machine operation. High load lifting and pulling, as well as multi-function operations are performed smoothly and with ease.

Model: ISUZU
4JJ1XDRAC-01



Engine Output

71.5 kW / 2,000 min⁻¹

Large Easy-to-See 10-Inch Colour Monitor

Important information is easy to read, and operations can be performed from a simple menu screen. The camera can also be easily checked from the large screen, improving safety.



A Jog Dial for Simple Operation

Multiple operations can be performed with the jog dial. They can be performed by simply turning, selecting, pushing, and confirming while navigating through the dial display. All operations can be smoothly performed while wearing gloves.



Advanced LED Backlight

Switches and dials utilise LED backlighting. This increases visibility at night and improves the ambiance of the interior.



New Console Tilting for Ease of Access and Exit

The left console has a safety lever to raise the console at a steep angle for ease of access and exit.



Automatic LED Door Light

The cab is equipped with a bright LED light that automatically lights up when the door is opened and when the key is turned off.



Purpose-Built Functionality. Fully Customised

HD Arm for Metal Demolition
Dedicated reinforced Heavy-Duty arm.

Multi-Use Dismantling Nibbler
Lightweight design allows for fine movements. Shaped for smooth grabbing, picking, cutting, and pulling.

Clamp Arm
Can secure large objects, and pinch small objects. The design of the arm allows work to be performed efficiently.

Boom Holding Valve
Hose burst protection prevents boom from falling in the event of hose rupture.



Puller
Shaped for convenient attachment to a harness

Grip
Rotates objects forwards or backwards that are grabbed by the clamp

Teeth
Allows objects to be crushed or cut

Anchor
Used to bend long objects

Dismantling Process Flow Chart

How the Car Dismantling Machine Works

1. Collecting Fuel, Fluids and Chlorofluorocarbon Gas

Remove fluids such as fuel, anti freeze, oils and chlorofluorocarbon gas



2. Parts Collection

Efficiently collect reusable parts



to Suit Scrap & Metal Demolition Needs.

Arm Holding Valve

Hose burst protection on arm improves operating safety.

HD Boom for Metal Demolition

Dedicated reinforced Heavy-Duty boom.

Boom Cylinder Cover

Prevents collisions from damaging the cylinder.

Boom Foot Cover / Center Cover

Prevents metal fragments from entering the cab.

Cab for Metal Demolition

The large glass skylight is equipped with a top guard.

Dedicated Equipment

- Double-sided grid type guard with a holder for work boots
- FOPS Level II top guard
- Air suspension seat
- 4-inch armrest
- Cab entry step

Counterweights + Additional Weights

Additional counterweights provide added stability.

3. Car Dismantling Process



After pre-processing, the car is sorted into raw components such as ferrous, non-ferrous and plastics



²⁹ Cu
Copper
63.546

¹³ Al
Aluminium
26.982

3. Processes After Removing Parts

Once thoroughly cleaned, the parts become good quality recycled parts



4. Volume Reduction Processes

After treating, the scrap cars are cut up and crushed or pressed into materials that meet industry needs



Blocks of material can then be distributed to smelting plants for recycling



A Multi-Dimensional Approach for Improved Reliability and Durability

HD Boom for Metal Demolition

A new HD boom was developed specifically for metal demolition that uses thick plating and reinforced materials in each part.

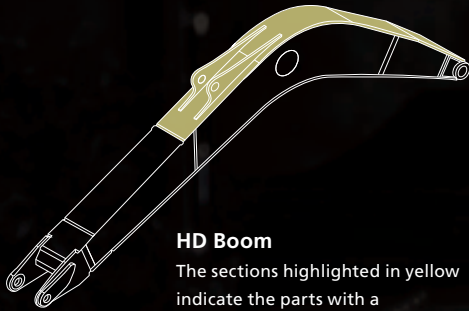

HD Boom

The sections highlighted in yellow indicate the parts with a dedicated design.

HD Arm for Metal Demolition

A new HD arm was developed specifically for metal demolition that has a reinforced lower plate and better steel-plate materials.



HD Arm

The sections highlighted in yellow indicate the parts with a dedicated design.

Damage-Resistant Center Cover for the Clamp Arm

The strength has been improved by using a thick plate and changing the shape of the center cover that protects the opening/closing mechanism for the clamp arm. The newly designed guard protects the nibbler from deformations due to collisions.



Equipment - Center Cover / Boom Foot Cover

Stops metal fragments from entering the machine from the foot of the boom and prevents the occurrence of hydraulic issues.



Center Cover

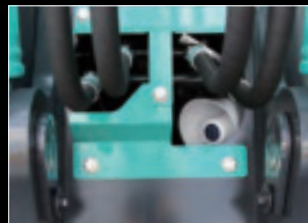

Boom Foot Cover

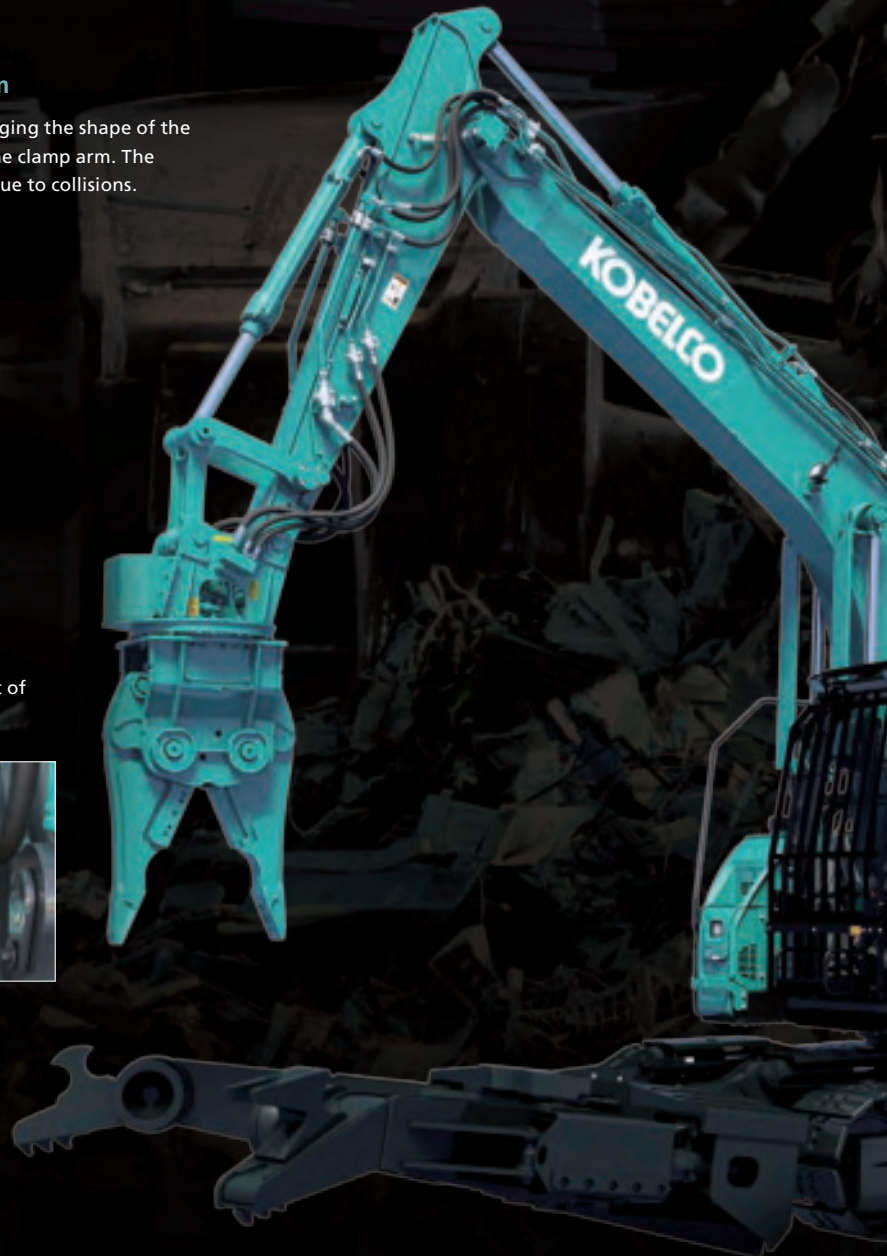

Renewed Usability and Comfort, Improved Work Efficiency

Air Suspension Seat



An air suspension seat manufactured by the German GRAMMER AG comes as standard equipment. It has superior shock absorption and can be used for long periods of time without causing fatigue. The included armrest is 4 inches wide.

Modern Cabin Design, Built for Today's Operator



Smartphone Holder



12 V Power Supply / USB Port



FM / AM Bluetooth® (hands free) Radio

**Bluetooth® is a registered trademark of the Bluetooth SIG Inc.

HCP Lever for Simultaneous Operations

The HCP (Hand-controlled proportional) lever has a slide switch on the left and right grips for opening/closing and rotating the nibbler. Fine movements can be easily performed, and clamp-arm movements can be performed simultaneously in combination with the foot pedal for increased work efficiency.

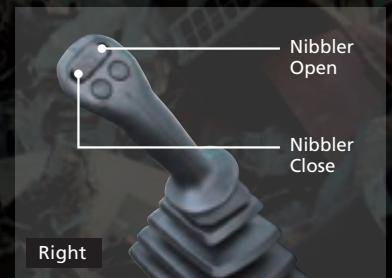
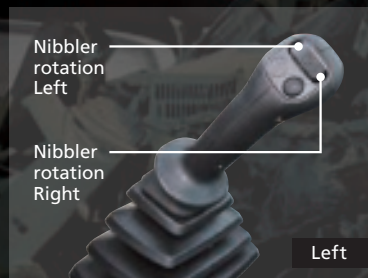

Stress-Free Work Performance

Superior Stability

An additional 580kg counterweight is included as standard equipment. High stability means less rocking of the body and more efficient operation.



More Reliable Lifting Power

The lifting power has been increased by hardening the boom and arm. Objects can be moved and pulled smoothly.

A New Hydraulic Control System with Improved Operability

Compared to regular excavators, the small stroke lever allows quick and accurate movements.

Functions and Equipment Designed for the Protection of Operators and Workers

Cab-Interference Prevention Apparatus that Prevents Collisions with the Nibbler

Angle sensors in the boom, arm, and idler link calculate the position and orientation of the multi-use dismantling nibbler. If the nibbler gets close to the cab, a warning will be displayed on the screen, and it will automatically stop if it enters the interference-danger zone.



Boom-Angle Sensor



Arm-Angle Sensor



Bucket-Angle Sensor



Cab Interference Warning



Cab for Metal Demolition that Includes a Top Guard

A new cab with a wiper and a large, glass skylight for a wide upper view. Standard equipment consists of a double-sided, radiator-shaped grid guard on the front, which does not obstruct the operator's field of vision, and a hinged top guard that allows easy access to clean the top glass. The front and right-side windows have shatterproof film applied. This protects the operator from scattering metal fragments. A front-side polycarbonate guard is available as an option.



Optional Front Polycarbonate Guard

This high-strength guard can block even small fragments. It is scratch resistant to maintain a clear view.



Improved Visibility for Increased Operator Safety

LED Lights for Improving Work Visibility

The excavator is equipped with bright LEDs on both sides of the boom, in 2 places on the top of the cab, and on the upper right of the body to ensure sufficient work visibility when working at night, during dusk, or when working inside.



2 Lights On the Boom



2 Lights On the Cab



Working Light On the Upper Body

Rear and Right-Side Images / Eagle-Eye View

The body has cameras on the rear, right, and left sides. The large colour monitor can be used to check the safety of the rear and right sides which cannot be seen directly. Selectable camera displays include the simultaneous rear- and right-side (direct or right-rotated) view, the simultaneous top-down rear and right side view, and the eagle-eye view, which adds the left view and shows all three directions simultaneously.



Eagle Eye View



Direct Right-Side View

Rear

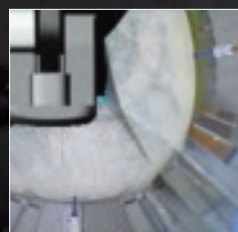

Top-Down View

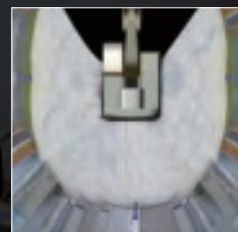

Eagle-Eye View



Rear Camera



Left Camera

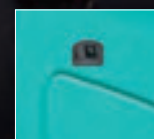

Right Camera



KOBELCO's Exclusive Integrated Noise & Dust Reduction Technology



Unbeatable Dust and Heat Protection

The iNDR filter stops dust from entering the machine, preventing radiator clogs and maintaining cooling performance. The iNDR filter has a shape that does not clog easily, and it can be used for long periods of time without overheating.

Superior Serviceability

Daily maintenance of the iNDR filter consists of simply a visual check. Cleaning is only necessary when significantly dirty. The filter can be easily removed without the need for tools, reducing the burden on workers and the time required for cleaning.

Impressively Quiet

The sound of the engine and cooling fan is reduced in the cab, and the unique absorptive structure achieves a high degree of silence. When operating inside, sounds are not sustained in the cab, and when working outside, the bother of nearby noise is minimised, reducing the stress of the operator.



The high-density mesh iNDR filter has a wave-shaped screen design which is resistant to clogging.

Equipment Designed Specifically for Metal Demolition



Bottom Cover of the Upper Body

Prevents objects from piercing the excavator from the bottom and protects internal components.



Under Cover of the Lower Body

The bottom surface of the lower car body is equipped with a steel-plate cover that protects the hydraulic travel system.



Boom Cylinder Guard

A steel-plate guard is equipped to protect the boom cylinder rod from metal fragments.



Fuel Inlet and Dustproof Cap

The dustproof cap prevents dust from entering.



Shoe-Holding Cab Guard

This space was added to hold work boots in order to keep the floor of the cab clean.



Public Address System

Communicate easily with site bystanders via the high sensitivity microphone and external loudspeaker.



Cab Entry Step

Equipped with a large step to make entering or exiting the driver's seat easy.



Remote Fuel Drain Cock

Allows fuel to be drained remotely, with easy ground-level access.



Fuel Fill-Up Pump

Refuel quickly and easily straight from any fuel tank with the remote mounted fuel fill pump.



Specifications

Engine

| Model | ISUZU 4JJ1XDRAC-01 |
|------------------|---|
| Type | Four cycle, water cooled, overhead camshaft, vertical in-line, direct injection type, with turbo-charger. |
| No. of cylinders | 4 |
| Bore and stroke | 95.4 mm x 104.9 mm |
| Displacement | 2,999 ml |
| Power output | 71.5 kW / 2,000 min ⁻¹ (ISO 9249 : with fan) |
| | 78.5 kW / 2,000 min ⁻¹ (ISO 14396 : without fan) |
| Max. torque | 354 N-m / 1,800 min ⁻¹ (ISO 9249 : with fan) |
| | 375 N-m / 1,800 min ⁻¹ (ISO 14396 : without fan) |

Hydraulic System

| Pump | |
|----------------------------|--|
| Type | Double variable displacement axial piston pumps with a gear pump |
| Max. discharge flow | 2 x 130 L/min 1 x 20 L/min |
| | Extra gear pump 1 x 60 L/min |
| Relief valve setting | |
| Excavating circuits (main) | 34.3 MPa |
| Travel circuit | 34.3 MPa |
| Swing circuit | 28.0 MPa |
| Pilot control circuit | 5.0 MPa |
| Nibbler (Crusher) circuit | Open & Close 24.5 MPa Rotation 20.6 MPa |
| Clamp arm circuit | Open & Close 24.5 MPa Up&Down 24.5 MPa |
| Main control valve | 12-spool |
| Oil cooler | Air cooled type |

Swing System

| | |
|-------------------------|------------------------------------|
| Swing motor | One fixed displacement piston pump |
| Parking brake | Wet multiple plate |
| Swing speed | 11.0 min ⁻¹ |
| Swing torque | 40.4 kN-m (SAE) |
| Tail swing radius | 1,610 mm |
| Min. front swing radius | 2,240 mm |

Travel System

| | |
|-----------------------|--|
| Travel motors | Variable displacement axial piston type x 2 pcs with Counter balance Valve |
| Travel brakes | Hydraulic brake |
| Parking brakes | Wet multiple plate |
| Travel shoes | 44 each side |
| Travel speed | 5.6 / 3.4 km/h |
| Drawbar pulling force | 138 kN (SAE J 1309) |
| Gradeability | 70% {35°} |

Cab & Control

| Cab |
|---|
| All-weather, sound-suppressed steel cab mounted on the silicon-sealed viscous mounts and equipped with a heavy, insulated floor mat.e |
| Control |
| Two hand levers and two foot pedals for travel |
| Two hand levers and two foot pedals for operation |
| Rotary-type electric throttle |

Refilling Capacities & Lubrications

| | |
|-----------------------|--------------------------|
| Fuel tank | 186 L |
| Cooling system | 17.0 L |
| Engine oil | 17.0 L |
| Travel reduction gear | 2 x 2.1 L |
| Swing reduction gear | 1.65 L |
| Hydraulic oil tank | 89.9 L (tank oil level) |
| | 192 L (hydraulic system) |
| DEF/AdBlue tank | 20.7 L |

Operating Weight & Ground Pressure

| | |
|------------------|-----------|
| Shoe width | 500 mm |
| Ground pressure | 64 kPa |
| Operating weight | 20,500 kg |

Front Attachment

| Model | KHE750PR-2 |
|--------------------------------|---------------------|
| Weight | 970 kg |
| Shearing force (blade center) | 255 kN |
| Crushing force (tooth-jaw tip) | 88.3 kN |
| Operating pressure | open/close 24.5 MPa |
| | rotation 20.6 MPa |

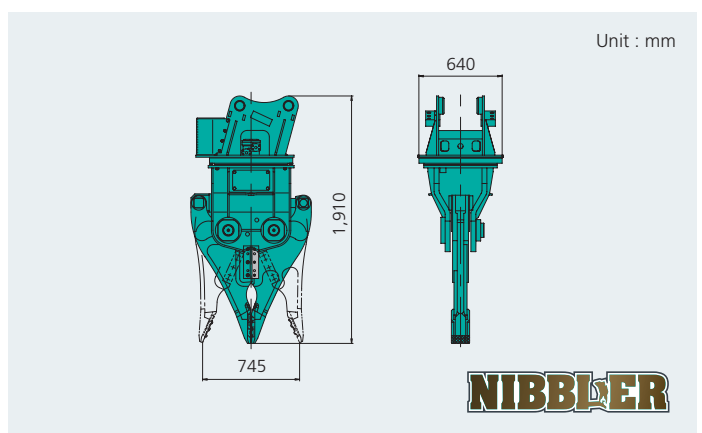



Dimensions

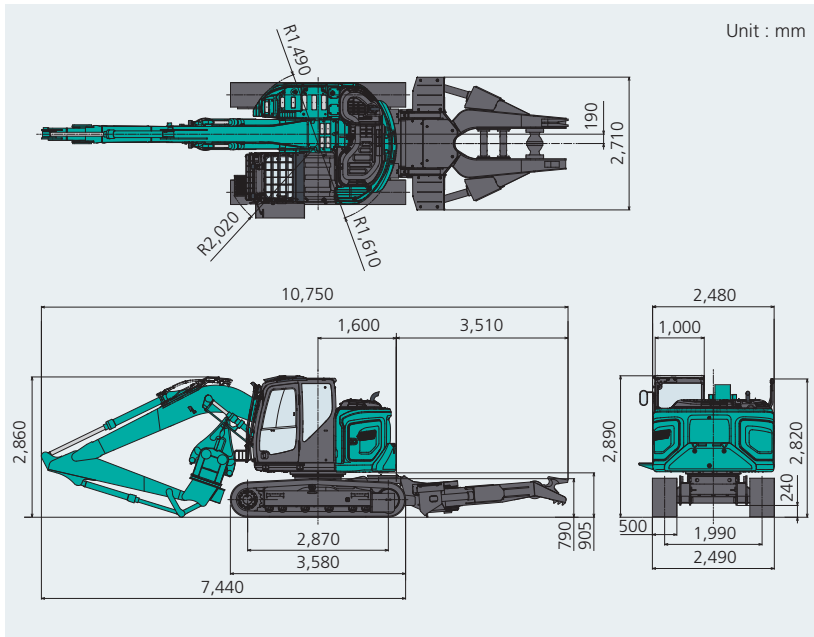

Working Ranges

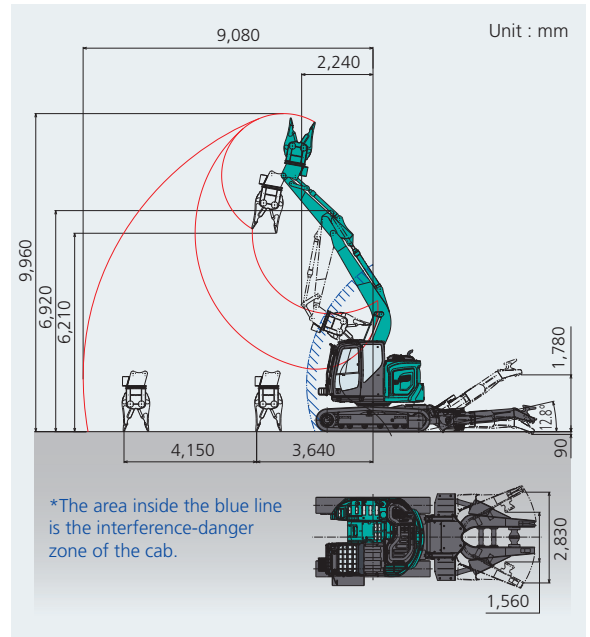

Standard Equipment

ENGINE

- ISUZU 4JJ1XDRAC-01 diesel engine with turbocharger and intercooler
- Auto Idle Stop
- Automatic engine deceleration
- Two 12 volt 88Ah batteries
- 24V-4kW starter
- 50-amp alternator
- Engine oil pan drain valve
- Two-stage air filter
- Proportionate engine accelerate
- Removable clean out screen
- Double element air cleaner
- Automatic low engine oil pressure shut down
- Side by side oil, hydraulic and engine radiators

HYDRAULIC

- Hydraulic oil cooler
- Hydraulic oil filter condition indicator
- Rotation and Nibbler circuits and piping

SWING SYSTEM & TRAVEL SYSTEM

- Swing rebound prevention system
- Straight propel system
- Two-speed travel with automatic shift down
- Sealed & lubricated track links
- 500mm flat shoes
- Grease-type track adjusters
- Automatic swing brake

MIRRORS, LIGHTS & CAMERA

- Left side rear view mirror, rear view camera, right and left side view camera
- Three front working lights (1 on uppercarriage, 2 on cab)
- Two attachment front working lights

CAB & CONTROL

- Two Hand Control Proportional levers, two foot pedals, pilot-operated
- Electric horn
- Control pattern changer (2-way)
- Cab door light (interior)
- Coat hook
- Large cup holder
- Detachable two-piece floor mat
- Air suspension seat with armrests
- Retractable 2-inch seatbelt
- Cab entry and engine access handrails
- Heater and defroster
- Intermittent windshield wiper with double-spray washer
- Sky light
- Front guard (grid type 2-face guard that opens for cleaning)
- Top guard level II (Meets ISO10262)
- Tinted safety glass and shatterproof film
- Pull-type front window and removable lower front window
- Easy-to-read 10-inch LED SCREEN (Multi display monitor)

CAB & CONTROL

- Automatic climate control
- Emergency escape hammer
- Radio (AUX & Bluetooth)
- 12V power source
- Hands-free telephone
- USB charging port
- Cab entry step

GUARDING & SAFETY

- Boom & arm cylinder holding valve
- Cab interference prevention system
- 9mm thick swivel guard
- 6mm thick upper frame under cover guards
- Boom cylinder guards
- Work boot tray
- Public address system
- GEOSCAN

Optional Equipment

- Poly-carbonate window guard
- Front guard (wire mesh guard 2 piece guard that opens for cleaning)
- 500mm track shoes

Note: Standard and optional equipment may vary. Consult your KOBELCO dealer for specifics.

GEOSCAN Excavator Remote Monitoring System

Total Support for Machines with Network Speed and Accuracy

GEOSCAN is a satellite-based system for receiving machine information. Manage your machines anywhere in the world using the internet. Location, workload and diagnostic data aid business operations.

Direct Access to Operational Status

Location Data

Accurate location data can be obtained even from sites where communication is difficult.

Operating Hours

A comparison of operating times of machines at multiple locations shows which locations are busier and more profitable.

Operating hours on site can be accurately recorded, for running time calculations needed for rental machines, etc.

Fuel Consumption Data

Data on fuel consumption and idling times can be used to indicate improvements in fuel consumption.

Graph of Work Content

The graph shows how working hours are divided among different operating categories, including digging, idling, traveling, and optional operations (N&B).



Maintenance Data and Warning Alerts

Machine Maintenance Data

Provides maintenance status of separate machines operating at multiple sites. Maintenance data is also relayed to KOBELCO service personnel, for more efficient planning of periodic servicing.

Security System

Engine Start Alarm

Sends a notification if the engine is started outside of pre-defined hours.

Area Alarm

Sends a notification if the machine leaves a pre-defined area.

Note: This catalogue may contain attachments and optional equipment that are not available in your area. And it may contain photographs of machines with specifications that differ from those of machines sold in your areas. Please consult your nearest KOBELCO distributor for those items you require. Due to our policy of continuous product improvements all designs and specifications are subject to change without advance notice. Copyright by **KOBELCO CONSTRUCTION MACHINERY CO., LTD.** No part of this catalogue may be reproduced in any manner without notice.

KOBELCO CONSTRUCTION MACHINERY CO., LTD.

5-15, Kitashinagawa 5-chome, Shinagawa-ku, Tokyo 141-8626 JAPAN
Tel: +81 (0) 3-5789-2146 Fax: +81 (0) 3-5789-2135
<https://www.kobelcocm-global.com/>

Inquiries To: